

LXXXIV

- 1) A is translated 2 squares up and 5 squares to the right.  
What are the new coordinates?

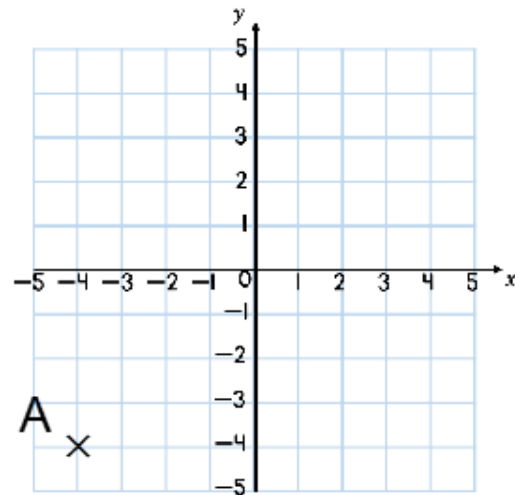

2)  $\frac{1}{5}$  of  = 15

- 3) Write the fractions in ascending order:

$$\frac{1}{4} \quad \frac{3}{7} \quad \frac{3}{18}$$

- 4) Adjacent angles on a straight line sum to \_\_\_\_\_

LXXXIV

- 1) A is translated 2 squares up and 5 squares to the right.

What are the new coordinates?

$(1, -2)$

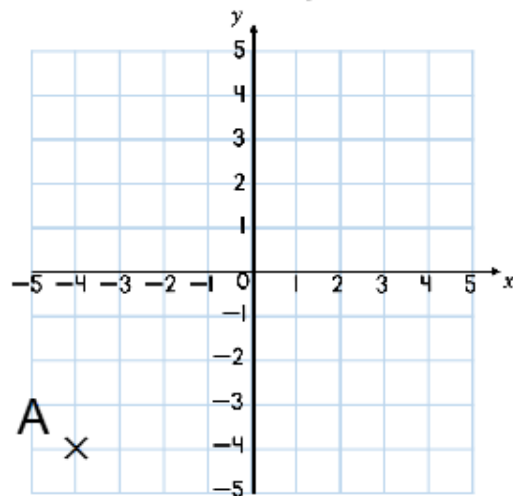

- 2)  $\frac{1}{5}$  of  $\boxed{75} = 15$

- 3) Write the fractions in ascending order:

$\frac{1}{4}$     $\frac{3}{7}$     $\frac{3}{18}$     $\frac{3}{18}$     $\frac{1}{4}$     $\frac{3}{7}$

- 4) Adjacent angles on a straight line sum to 180°

# Year 6

Monday 11<sup>th</sup> January 2021

## Maths

LO: understanding translation

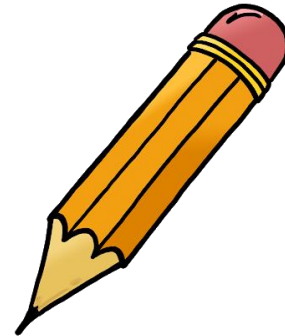

1) Write the coordinates of point A and B.

2) Plot the coordinate  $(0, -4)$

3) Plot the coordinate  $(-3, -7)$

4) Which quadrants are the points in?

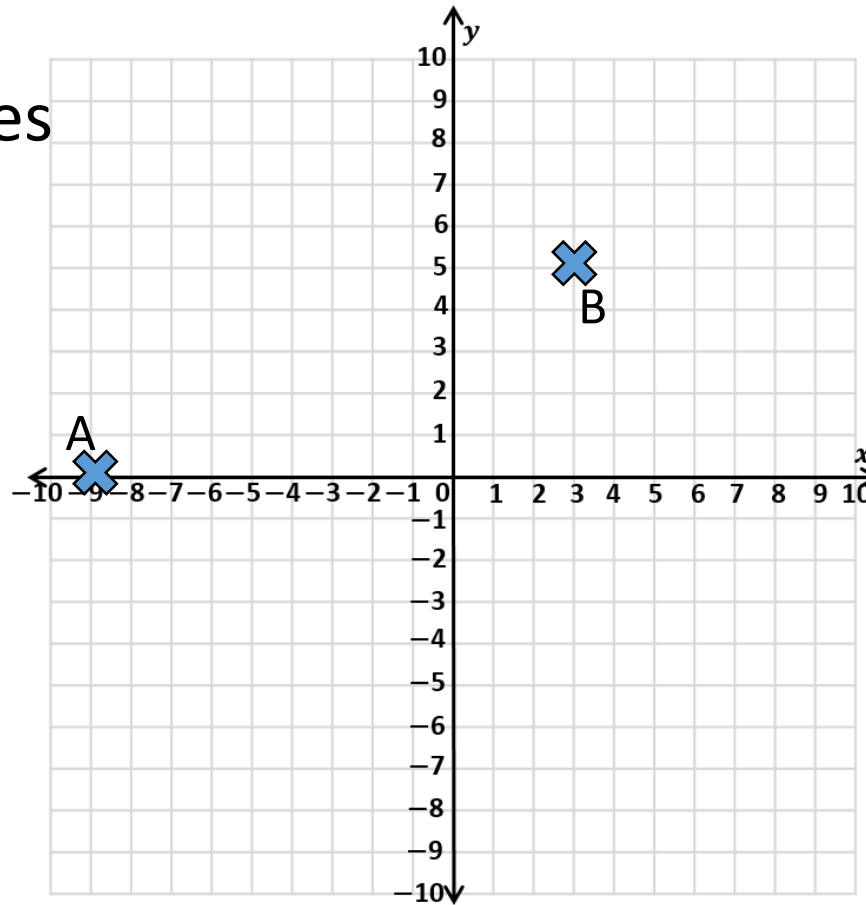

1) Write the coordinates of point A and B.

A  $(-9,0)$       B  $(3,5)$

2) Plot the coordinate  $(0,-4)$

3) Plot the coordinate  $(-3,-7)$

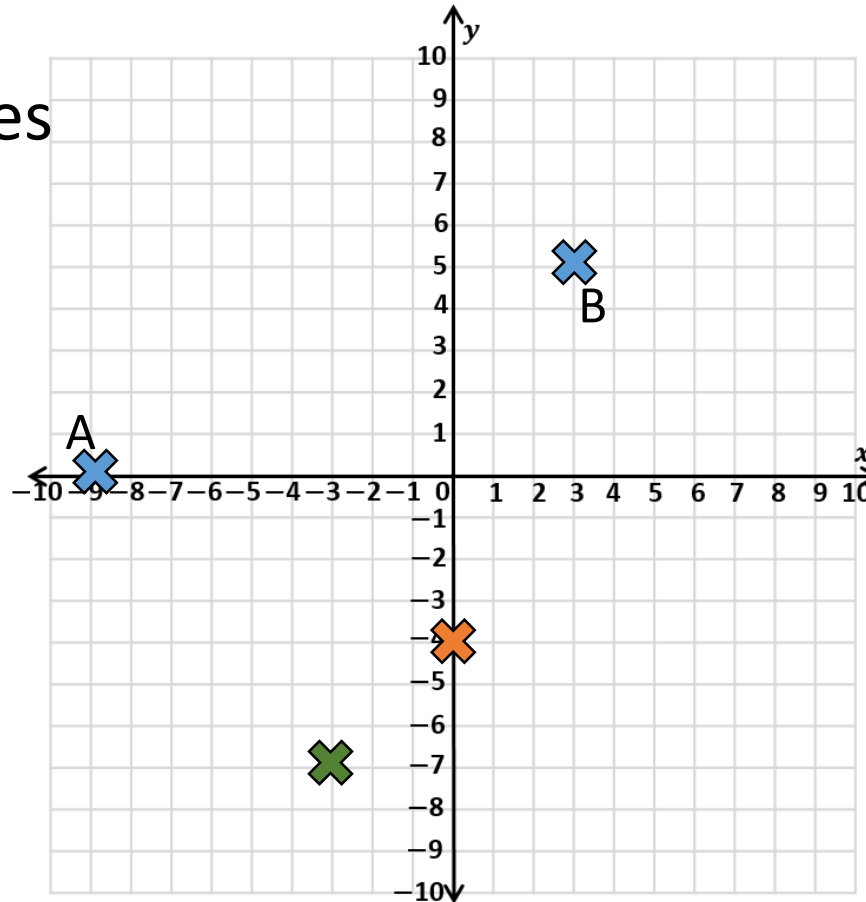

4) Which quadrants are the points in?

1<sup>st</sup> quadrant      3<sup>rd</sup> quadrant

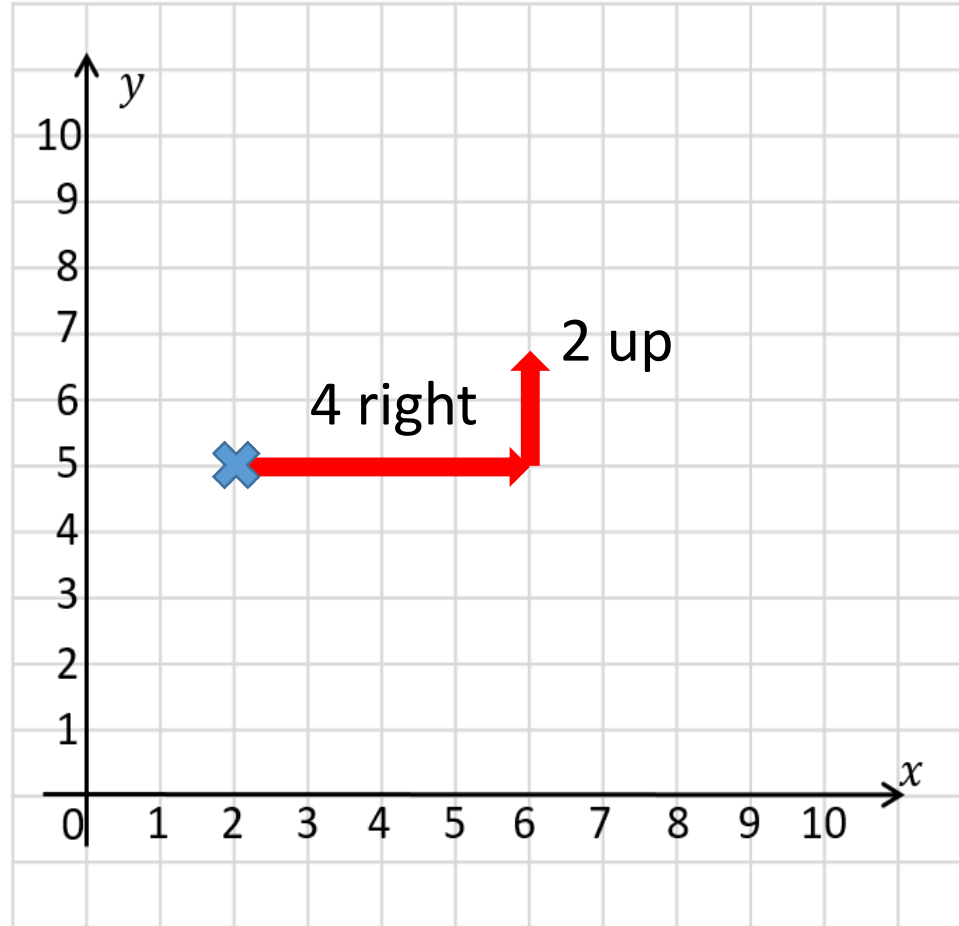

The point has been translated 4 right and 2 up.

Have a think

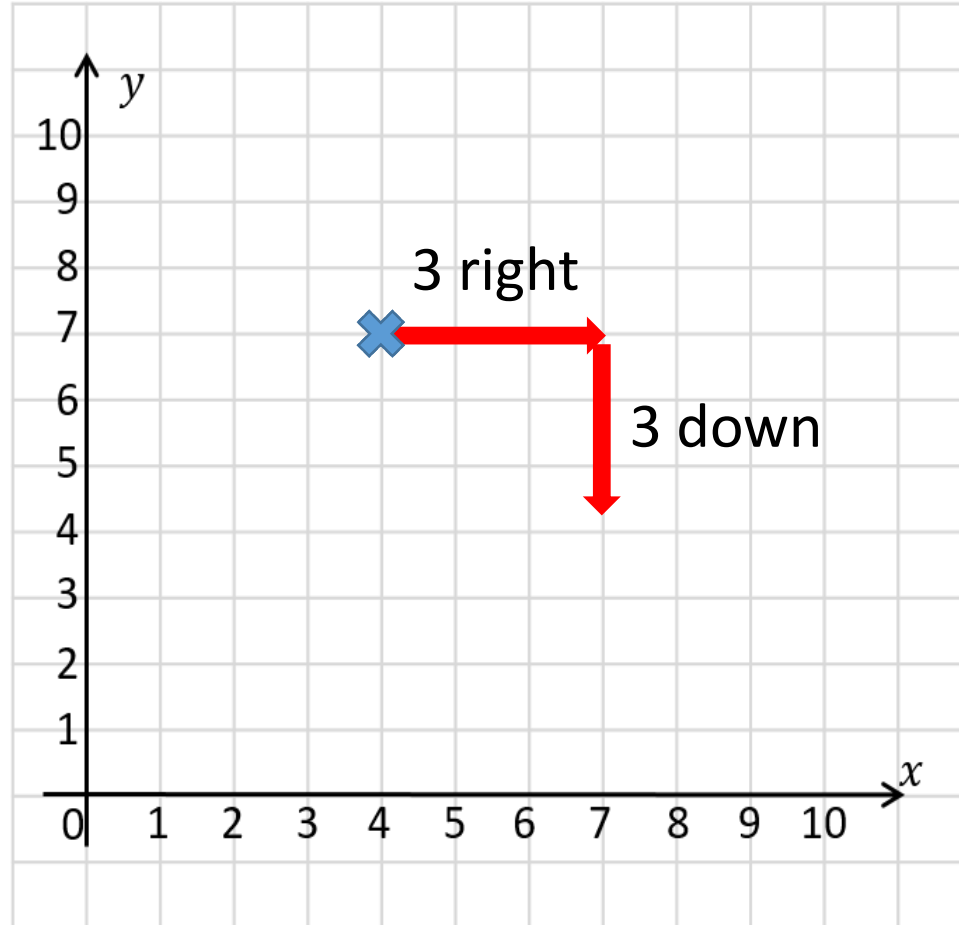

Can you describe the translation?

Can you describe the translations?

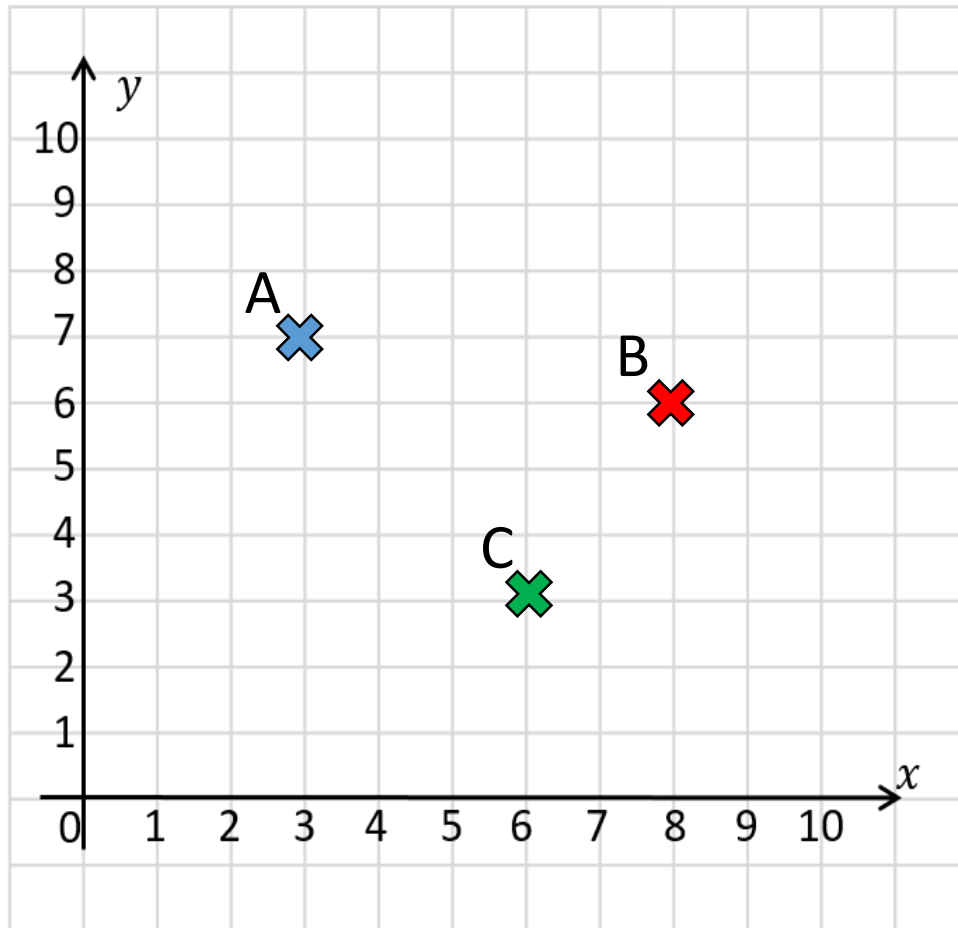

Have a think

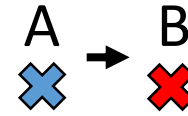

right  down

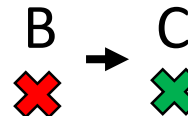

left  down

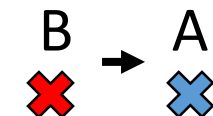

left  up



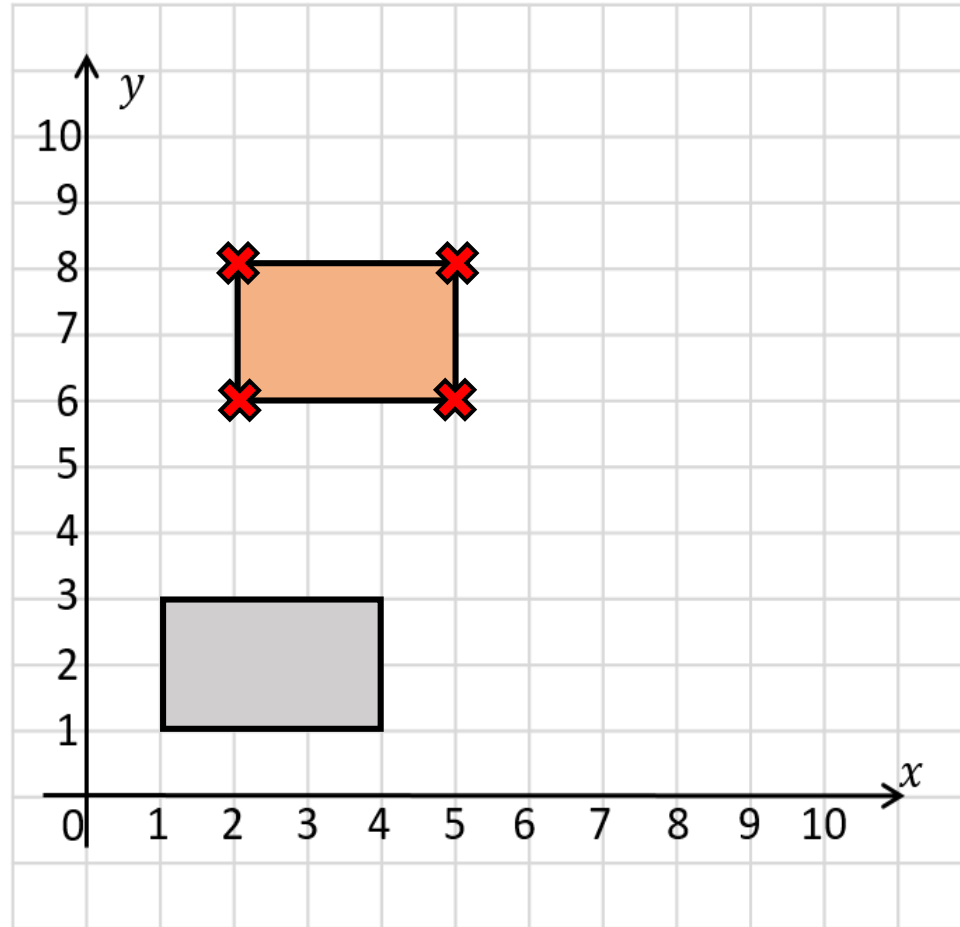

Translate the rectangle 1 left and 5 down.

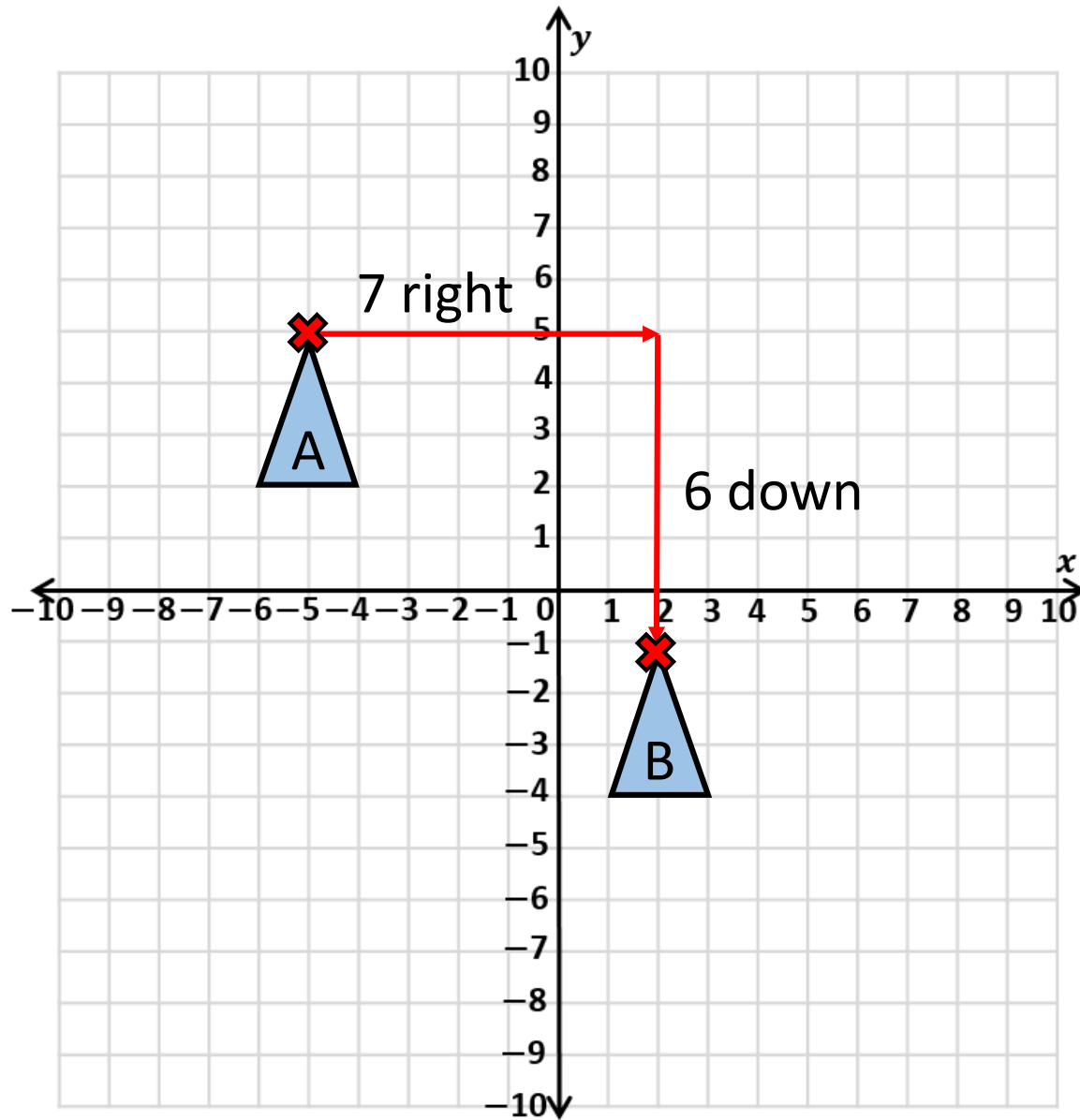

Have a think

What is the translation of triangle A to triangle B?

Translate shape A 3 left and 7 down

Have a think 

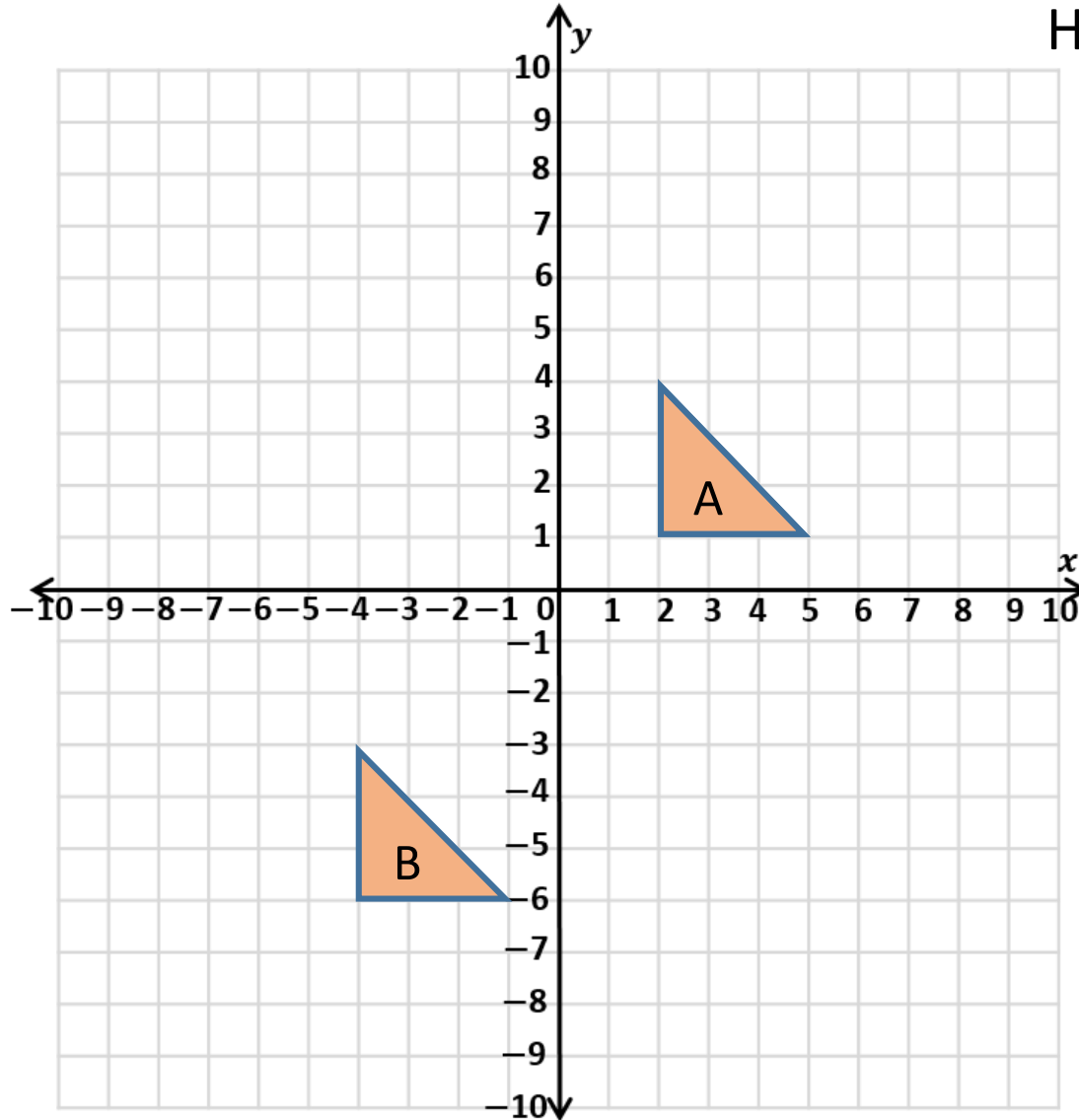

I think  
I've got  
this one!



Translate shape A 3 left and 7 down

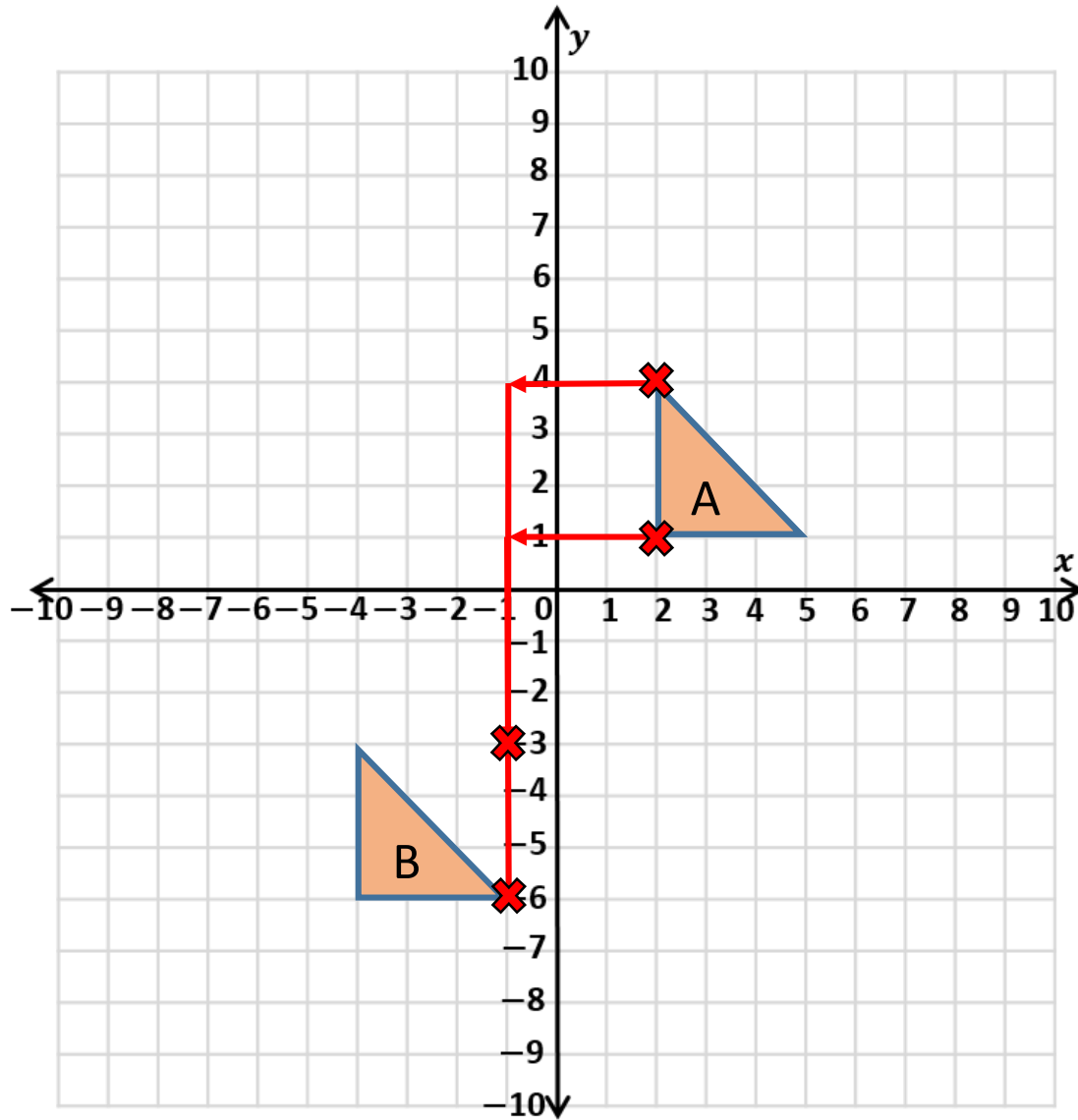

# Year 6

Monday 11<sup>th</sup> January 2021

## Maths – Independent Work

LO: understanding translation

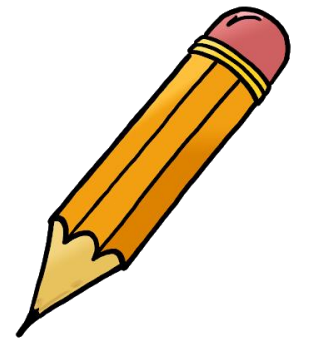

# Translations

1

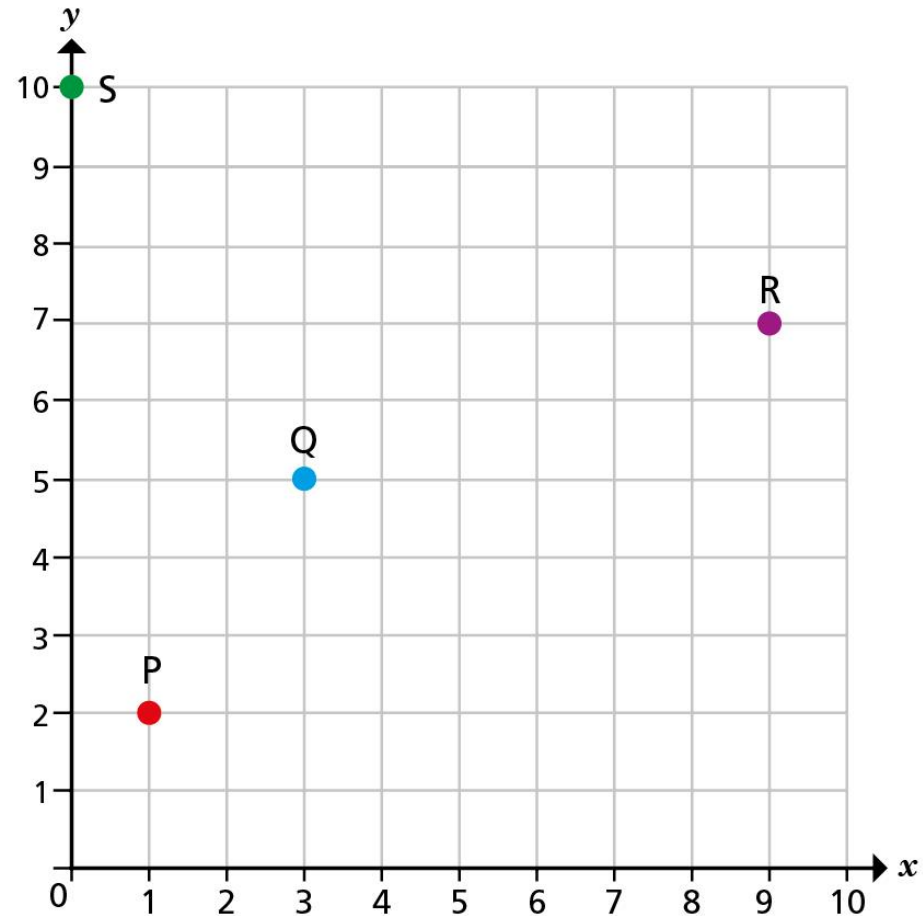

**1** Describe the translations.

- a) From P to Q is  right and  up
- b) From Q to R is  right and  up
- c) From R to S is  left and  up
- d) From S to P is  \_\_\_\_\_ and  \_\_\_\_\_
- e) From Q to P is  \_\_\_\_\_ and  \_\_\_\_\_
- f) From R to Q is  \_\_\_\_\_ and  \_\_\_\_\_
- g) From S to R is  \_\_\_\_\_ and  \_\_\_\_\_
- h) From P to S is  \_\_\_\_\_ and  \_\_\_\_\_

2

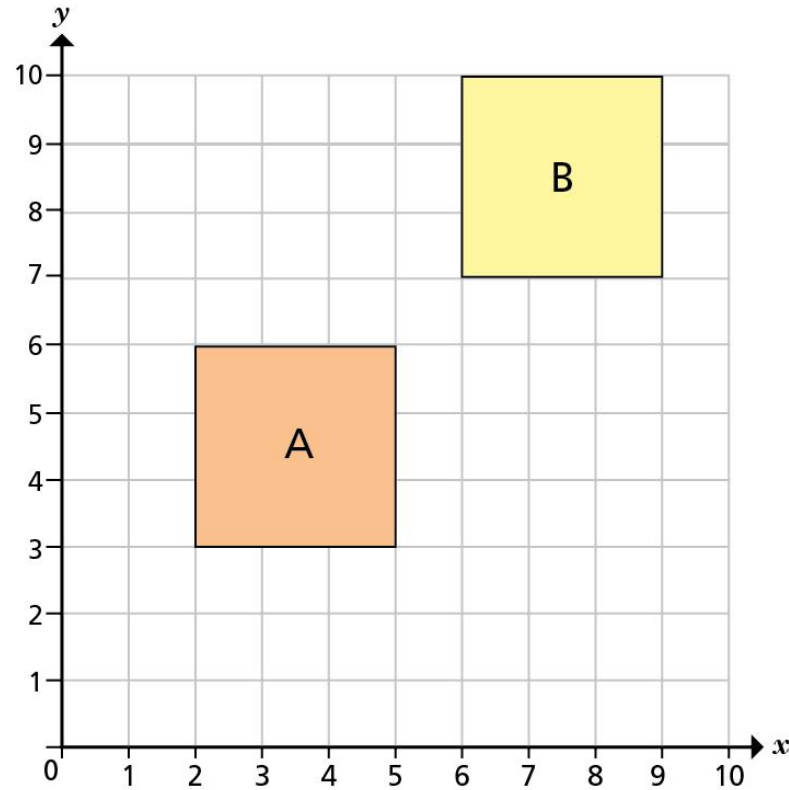

The translation  
from A to B is  
1 right and 1 up.

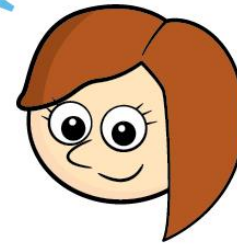

Do you agree with Rosie? \_\_\_\_\_

Explain your answer.

---





- 3 Translate the triangle 6 left.

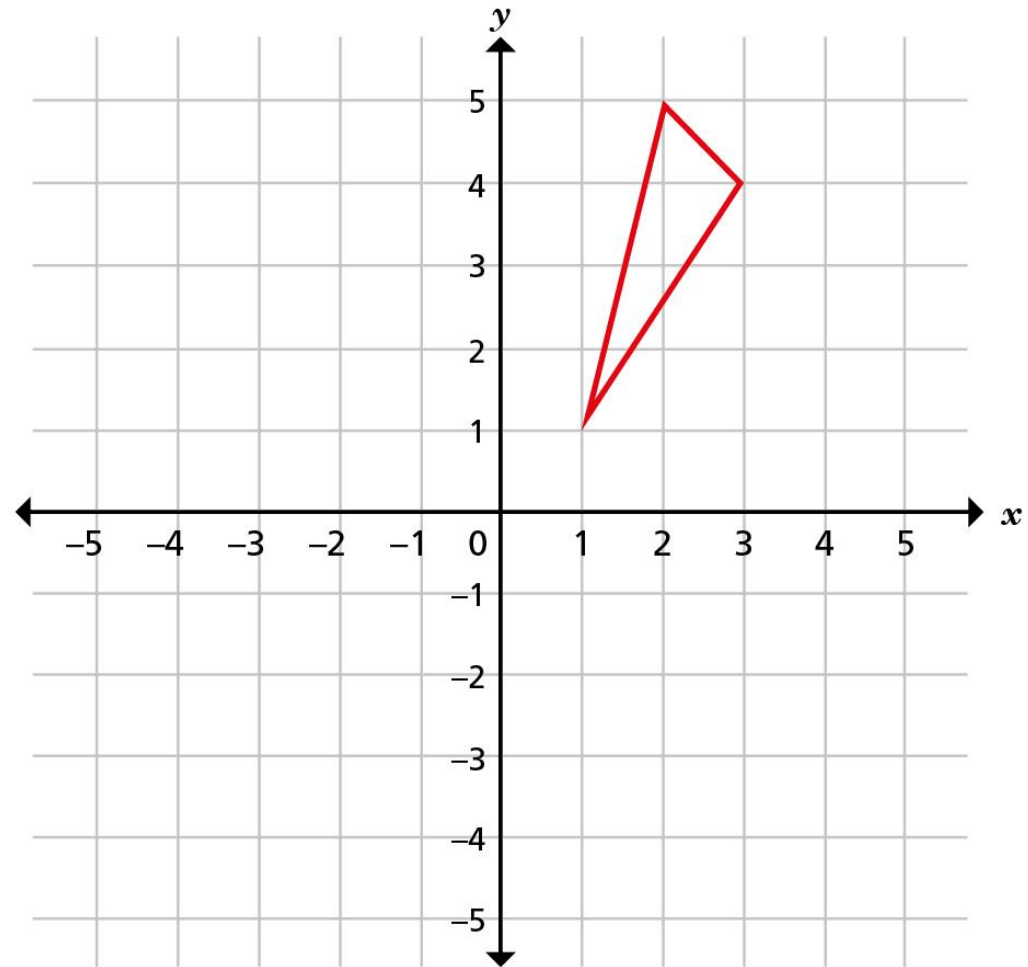

# SATS Buster EXT

Q7. Here is a shaded square on  $x$  and  $y$  axes.

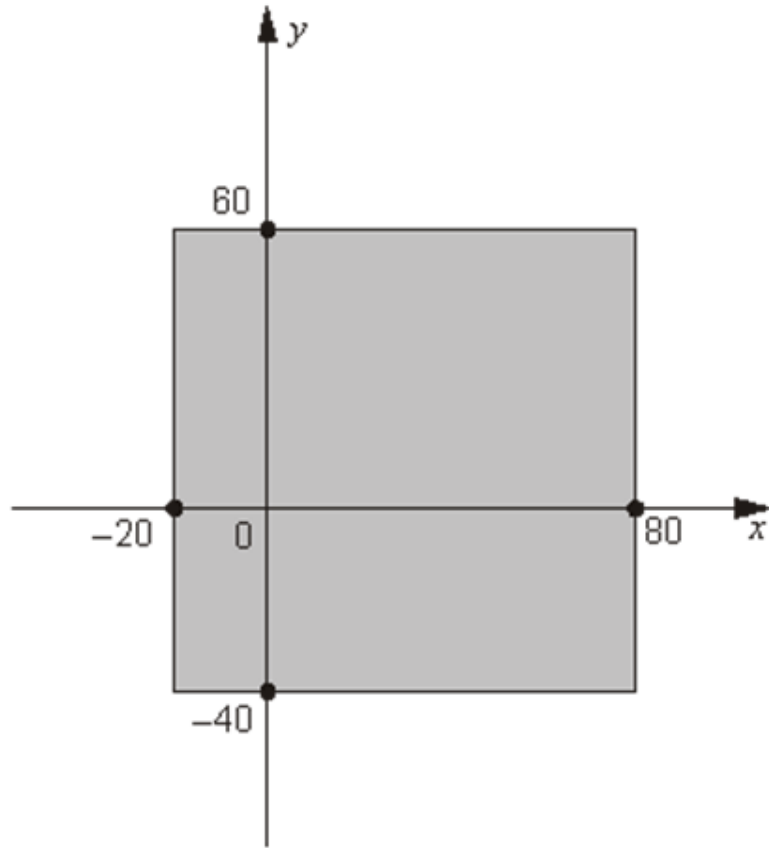

For each of these points, put a tick (✓) to show if it is inside the square or outside the square.

*Handwritten mark*

	<u>inside</u> the square	outside the square
(50, 70)	<input type="checkbox"/>	<input type="checkbox"/>
(60, -30)	<input type="checkbox"/>	<input type="checkbox"/>
(-10, 50)	<input type="checkbox"/>	<input type="checkbox"/>
(-30, -30)	<input type="checkbox"/>	<input type="checkbox"/>



The next two slides contain the answers. Only go ahead when you have finished. Reflect on what you have understood. Remember you can to ask questions at the class Q & A.



shutterstock.com • 1692570844

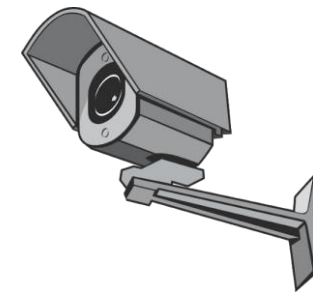

# Translations

1

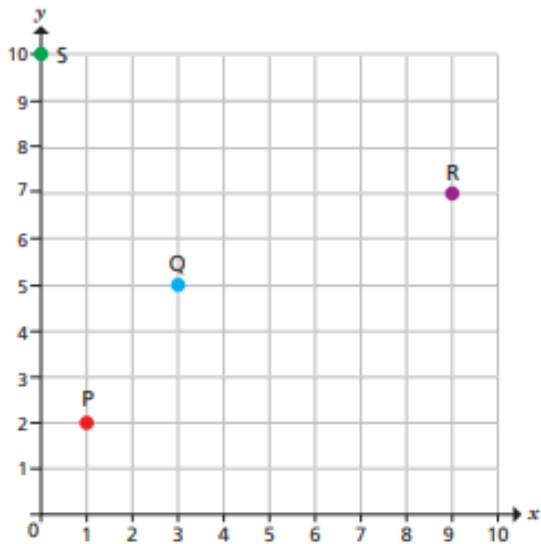

Describe the translations.

- a) From P to Q is  right and  up
- b) From Q to R is  right and  up
- c) From R to S is  left and  up
- d) From S to P is  right and  down
- e) From Q to P is  left and  down
- f) From R to Q is  left and  down
- g) From S to R is  right and  down
- h) From P to S is  left and  up

2

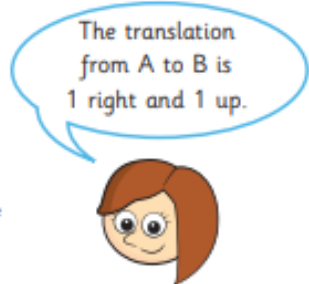
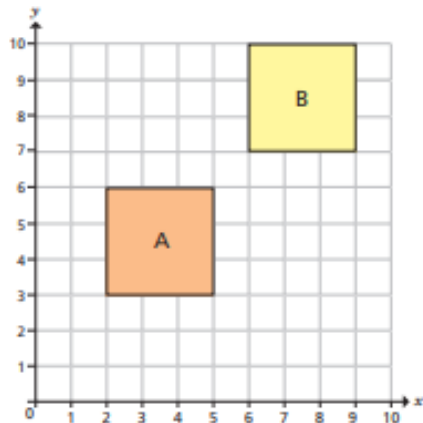

Do you agree with Rosie? No

Explain your answer.

She has looked at the corners closest to each other not the corresponding corners on each shape.

3

Translate the triangle 6 left.

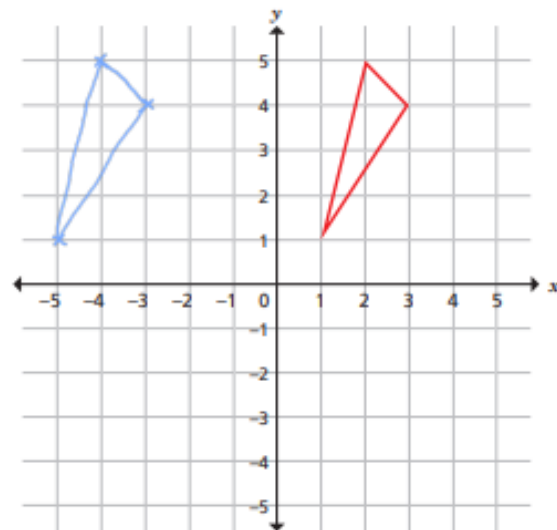

# SATs Buster EXT - ANSWER

Q7. Here is a shaded square on  $x$  and  $y$  axes.

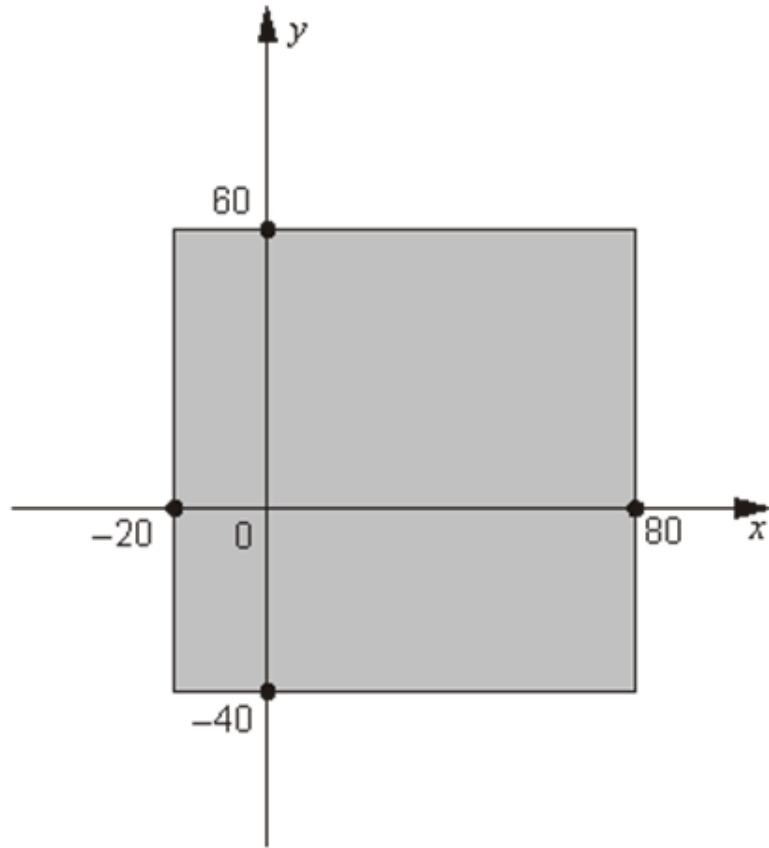

For each of these points, put a tick (✓) to show if it is inside the square or outside the square.

	<u>inside</u> the square	outside the square
(50, 70)	<input type="checkbox"/>	<input checked="" type="checkbox"/>
(60, -30)	<input checked="" type="checkbox"/>	<input type="checkbox"/>
(-10, 50)	<input checked="" type="checkbox"/>	<input type="checkbox"/>
(-30, -30)	<input type="checkbox"/>	<input checked="" type="checkbox"/>